

# FIGURE 1 - Options for Electrical and Water Discharge Line Locations UNH/Durham Water System

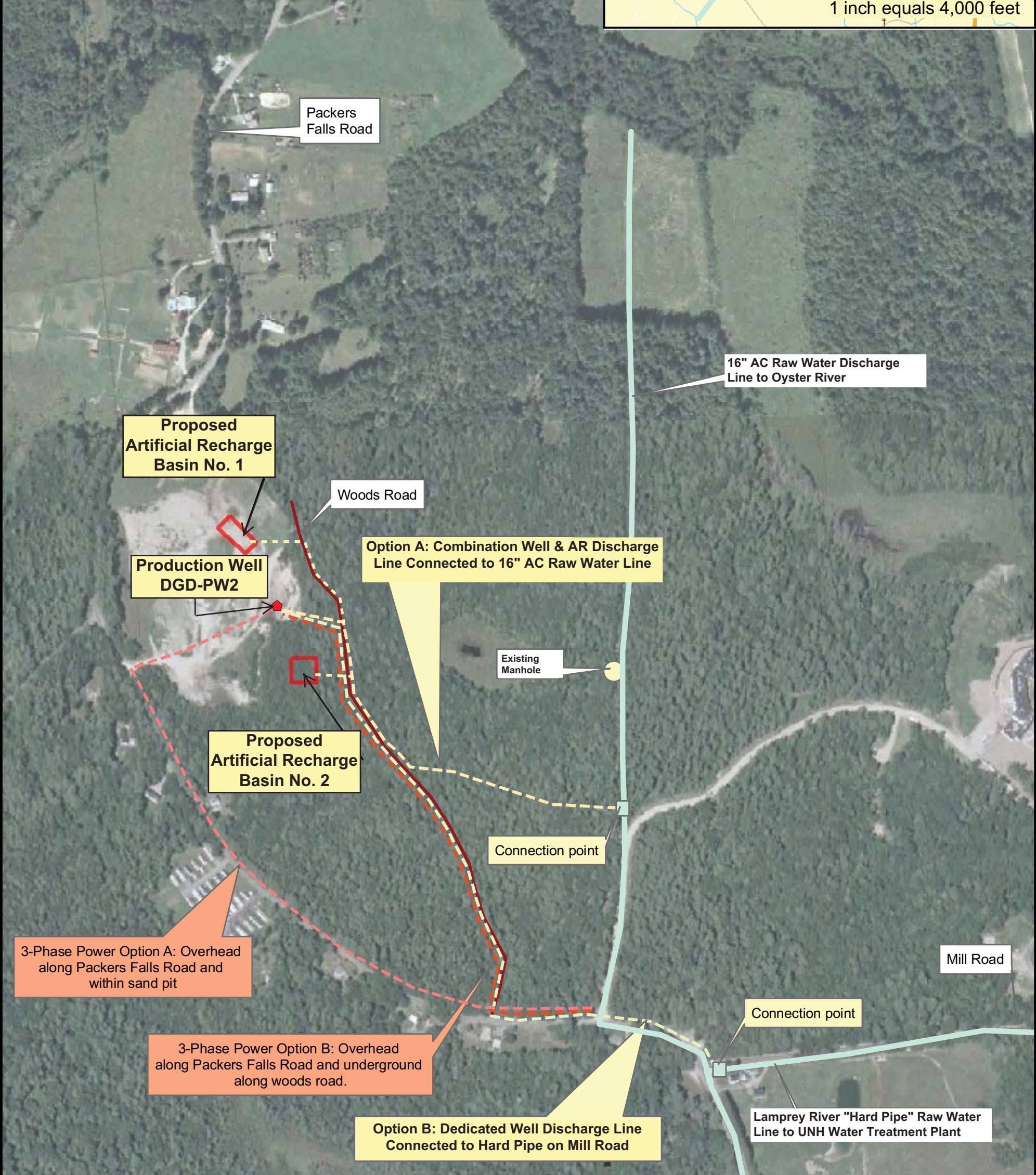
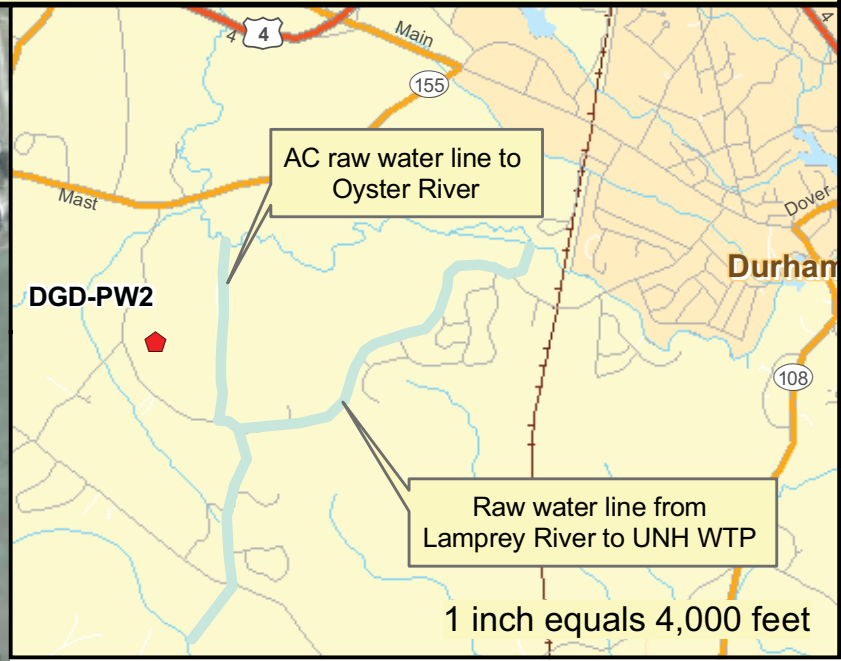
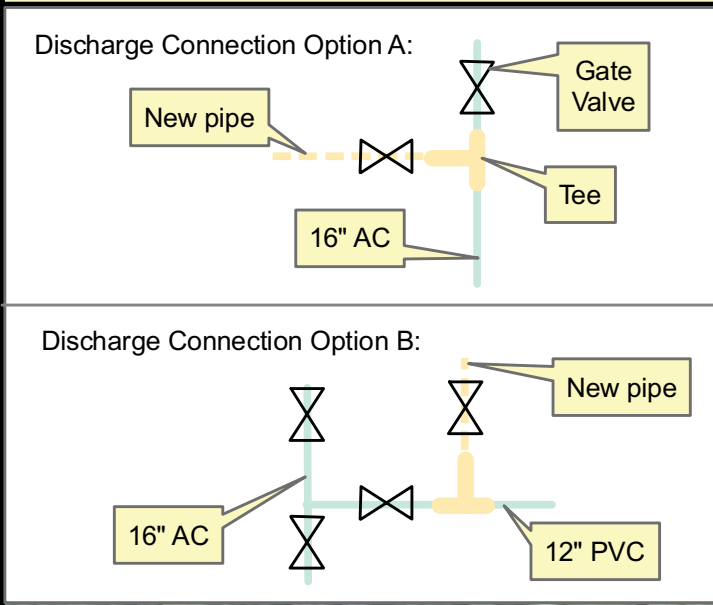

1 inch equals 400 feet

**FIGURE 1**  
*Emery & Garrett Groundwater, Inc.*